

Application 02

Mixing valve-heating circuit
Single stage burner
Domestic hot water

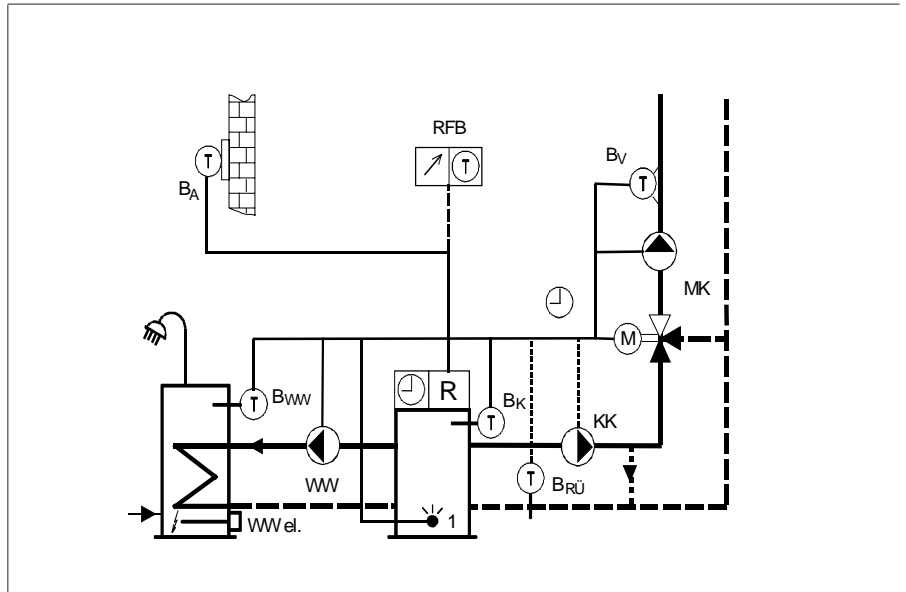

Application

Mixing valve-heating circuit for outside driven and/or room temperature driven control of the boiler temperature. (Sensor BRÜ connected -> limitation of return temperature)
A **single stage burner** and the **domestic hot water** with loading pump are controllable.

Hint

Circuit for floor heating : room temperature controlled regulation is forbidden! The value of the return low limit temperature is adjustable with the "boiler low limit" potentiometer.

Installation / wiring diagram

Wire according to application diagram or total current flow plan. Connection through specialists according to local regulations. The temperature sensor- and remote control-connections to the controller are supplied with low voltage protection. It is advantageous to lay these separate from the power supply cables.

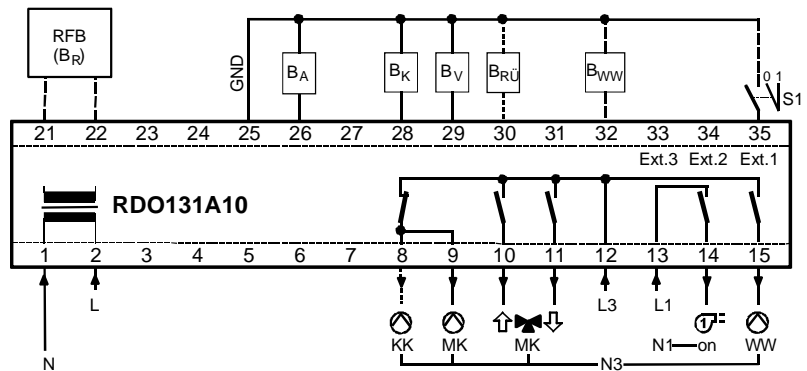



- S1 : External standby heating (switching off the heating operation)
- 0 = Controller operation mode not influenced
- 1 = Heating blocked and hot water loading blocked ; frost protection active

Controller configuration:

Ext.3 (33)	Ext.2 (34)	Ext.2 : (terminal 34) Ext.3 : (terminal 33)	-- = open X = connected to GND
X	--	Direct boiler-heating circuit	
--	--	Mixing valve-heating circuit (with or without limitation of return temp.)	
--	X	Mixing value-heating circuit for a floor heating-circuit and a direct boiler-heating circuit (auxiliary-heating circuit) for radiators with thermostat valve connected in series. (The Pumps will be energized with the same relay)	
X	X	Mixing valve-heating circuit (with or without limitation of return temperature) without boiler control. (by external "fixed value"-control of boiler; i.e. through boiler thermostat)	



Parameter list

Parameter	Adjustment	Factory	Min.	Max.	Installation value	Dim.
Boiler circuit						
control action		2-point				
switching differential (SD1)	Potentiometer 	8	4	12		K
boiler low limit (TKmin)	Potentiometer 	30	0 / 20	50		°C
on activation of limitation of return temperature: return temperature low limit (TRÜmin)	(TKmin > TRÜmin + 5K)					
(O = boiler start up and hot water discharge protection, OFF)						
boiler maximum limit (TKmax)	fixed	90				°C
minimum burner running time	fixed	2				min
Mixing valve-heating circuit						
control with PI-characteristic		3-point				
mixing valve running time	fixed	4	3	5		min
slope mixing valve-heating circuit (S)	Potentiometer 	1	0,2	3		
heating curve fixed-point	fixed	20				°C
difference TK-TV (elevation of boiler temperature)	4 + 0.5xSD1	(8)				K
overrun time heating circuit pump	fixed	4				min
summer operation interval heating circuit pump	fixed	on				
Domestic hot water circuit (WW-circuit)						
priority of hot water loading	fixed	half priority				
overrun time hot water loading pump	fixed	2				min
set value hot water temperature	Potentiometer	50	♻ / 40	70		°C
(with position : ♻ = frost protection)						
set value hot water temperature "frost protection"	fixed	5				°C
switching differential	fixed	6				K
elevation of boiler temperature (compared to hot water set value)	fixed	20				K
Values						
set value room temperature "normal"	Potentiometer	20	14	26		°C
set value room temperature "reduced" (= f[room temp. "normal"])	Potentiometer	-6	-2	-10		K
set value room temperature "frost protection"	fixed	5				°C
insert point of automatic day heating limit	f[S and room influence]					
system frost protection temperature (= f[outside temperature])	fixed	1				°C
room influence (B _A &B _R : room temperature influence)	fixed	25				%
(only B _R : room temperature regulation)	fixed	150				%

Pos	Unit	Type	Pcs:
	We recommend: Heating controller DOMOTESTA Heating controller DOMOTESTA	Daily clock, with spring reserve; LED indication Weekly clock, with spring reserve; LED indication	RDO131A100 RDO131A102
B _A	Outside temperature sensor	10kΩ NTC; IP40; Screw terminal	FT12A
B _V	Clamp-on temperature sensor - strap for clamp-on sensor	1kΩ PTC; IP40; Screw terminal	FT1A ZB126
B _K	Immersion temperature sensor Cable, temperature sensor	1kΩ PTC; IP40; Screw terminal 1kΩ PTC; IP54; l=1,6m; Tmax=120°C 1kΩ PTC; IP54; l=2,5m; Tmax=120°C	FT2A RFT203A16 RFT203A25
B _{WW}	Cable, hot water sensor	1kΩ PTC; IP54; l=4,0m; Tmax= 80°C	RFT213A40
RFB	Room remote control Room remote control	like RFB411A with new case Wall mounting; 10kΩ NTC Room set value correction; Program switch ("normal"/"Auto"/"reduced")	RFB410A RFB411A
B _R	Room sensor Room sensor	like RFT016A02 with new case Wall mounting; 10kΩ NTC (white)	RFT410A RFT016A02
	Connector strip for AMP Connector strip with screw terminals Base-plate 1 Accessory for base plate	2x15 terminals; without AMP-knife 2x15 terminals; wire cross section 2x1,5mm² with screw connector strip 2x15 Connection area expansion for cable glands	RZB500A RZB510A RZB520A RZB521A
RFV	Detector multiplier	230VAC; Sensor-Inputs : 1xNTC; 3xPTC max. 5 controllers per output connectable)	RFV400A
MK	Three-port slipper valves Four-port slipper valves Control motor for slipper valves	Various diameters ; max. 6 bar; 110°C Various diameters ; max. 6 bar; 110°C Torque 10 Nm; 280s; 230VAC (with universal mounting set for Elesta slipper valves)	H3G.../H3F... H4G.../H4F... NR230-22B
	Valves	On request	

